

# CAR & ADAS

Automotive scan tools and solutions for the calibration



**TEXA**

# ADVANCED DIAGNOSTICS FOR ALL MAKES

TEXA offers unbeatable coverage combined with the best return on investment in diagnostics. TEXA tools are made with the utmost quality materials and attention to detail.

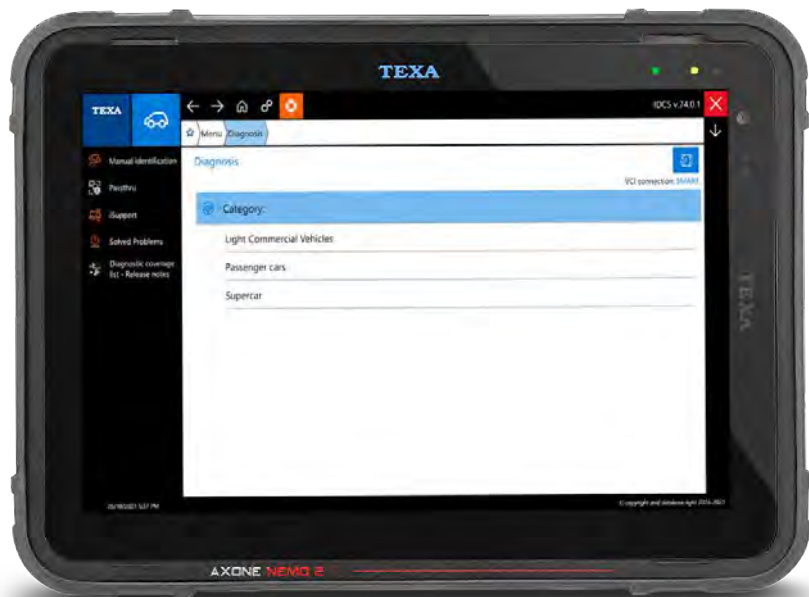

AXONE NEMO 2

Navigator Multihub



*TEXA's solutions match OEM specifications to provide **accurate** calibrations and unbeatable **coverage**.*

## SUPERCAR

ALFA ROMEO  
ASTON MARTIN  
BENTLEY  
BUGATTI  
FERRARI  
FORD  
LAMBORGHINI  
MASERATI  
MCLAREN  
MORGAN  
PAGANI  
PORSCHE  
ROLLS ROYCE

## PASSENGER CARS

ABARTH  
ACURA  
ALFA ROMEO  
AUDI  
BMW  
BUICK  
CADILLAC  
CHEVROLET  
CHRYSLER  
DODGE  
FIAT  
FORD  
GENESIS  
GMC  
HONDA  
HUMMER

HYUNDAI  
INFINITI  
JAGUAR  
JEEP  
KIA  
LAND ROVER  
LEXUS  
LINCOLN  
LOTUS  
MAZDA  
MERCEDES-BENZ  
MERCURY FORD  
MINI  
MITSUBISHI  
NISSAN  
PLYMOUTH  
SAAB  
SATURN

SCION  
SMART  
SUBARU  
SUZUKI  
TOYOTA  
VOLKSWAGEN  
VOLVO

## LIGHT COMMERCIAL VEHICLE

CHEVROLET  
DODGE  
FORD  
FREIGHTLINER  
GMC  
MERCEDES-BENZ  
NISSAN

# WHY SHOULD I CHOOSE TEXA?

TEXA is a global leader in the design, development, and production of multi-brand diagnostic tools. These services include, but are not limited to, ADAS: Radar and Camera Calibration Kit, Vehicle Communication Interfaces, A/C Recovery Machines, Sanitation Solutions, and TEXA IDC5 CAR Software which provides access to functions such as reading parameters and errors. Activation of components, settings, and ADAS calibrations (both static and dynamic).

TEXA offers the Navigator TXT MULTIHUB, which is the only VCI (vehicle communication interface) of its kind that can scan any vehicle from cars, trucks, bikes, and boats, to agricultural, all-terrain, and construction vehicles using IDC5 software.

TEXA offers an award winning, military-grade tablet that is engineered flawlessly to work in extreme conditions. Equipped with a magnesium chassis and touch screen made with gorilla glass, this rugged and durable tablet is the perfect choice for those working on all types of vehicles.



# THE TEXA TABLET

## AXONE NEMO 2

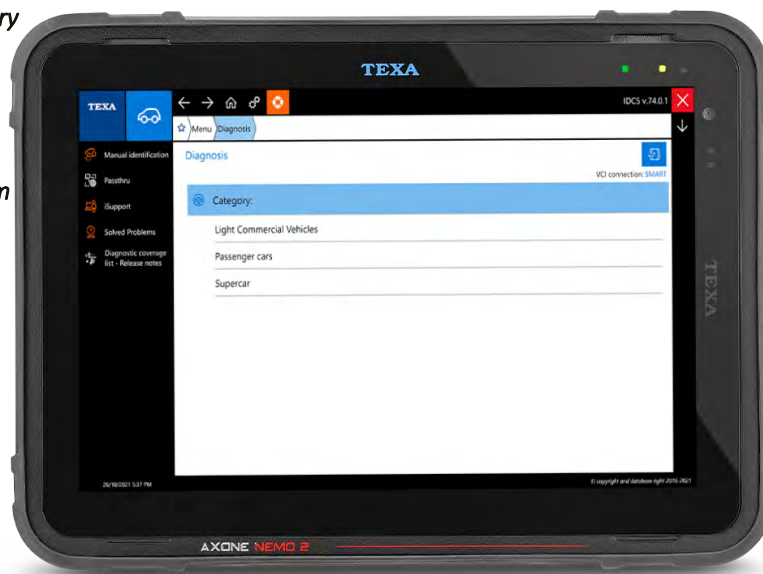

NEW



8 GB RAM Memory  
DDR4

NEW



CPU Intel® Pentium  
N5000

NEW



Bluetooth® 4.2

NEW



256 GB Storage  
PCIe

NEW



2 Cameras  
Rear: 13MP AF with Flash  
Front: 2MP

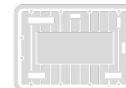

Magnesium  
casing



12" Gorilla® Glass  
DISPLAY



2160x1440 pixel  
resolution

NEW



Graphics card  
Intel UHD 600

## Nearly Indestructible Packed with features.

TEXA offers an award winning, military grade tablet that is engineered flawlessly to work in extreme conditions. Equipped with a magnesium chassis and touch screen made with gorilla glass. This rugged, splash-proof, and durable tablet is the perfect choice for those working on all types of vehicles. Using the Nemo 2 with IDC5 software offers a complete, practical, intuitive and extremely fast communication with light duty, medium duty, passenger cars and all other vehicles. It guides the technician through all diagnostic steps, from error detection to its solution. Always in a practical, safe and professional way.

# TWO DIFFERENT SCANNER OPTIONS



## TXT MULTIHUB

The multi-environment tool.

TXT MULTIHUB is equipped with a special reinforced body with anti-shock corners. Its certified protection level is IP53, resisting splashes of water and dust. This tool sports pass-through capabilities, built in DoIP, OLED display, built in WiFi hotspot and more. TXT MULTIHUB is the only diagnostic tool capable of scanning cars, heavy-duty vehicles, motorcycles, boats, agricultural and construction vehicles.

## NAVIGATOR NANO S

A trusted solution for cars and supercars

The NANO S is a surprisingly light and convenient to use fully bi-directional vehicle communication interface, built specifically to diagnose cars and super cars. Nano S offers expansive coverage on Passenger Cars (Domestic, Asian, and European).



# TEXA IDC5 Software



## GLOBAL SCAN



Global scan of all ECUs with live data and test drive functions.



## DTC PAGE

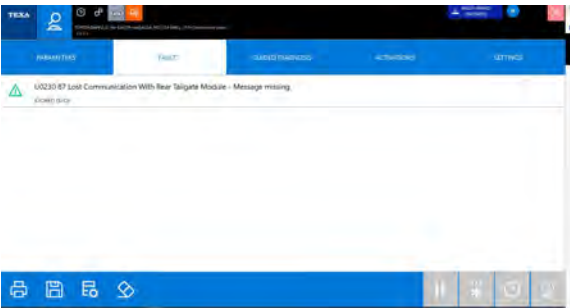

Includes listing of all active and memorized fault codes.



## ACTIVATION

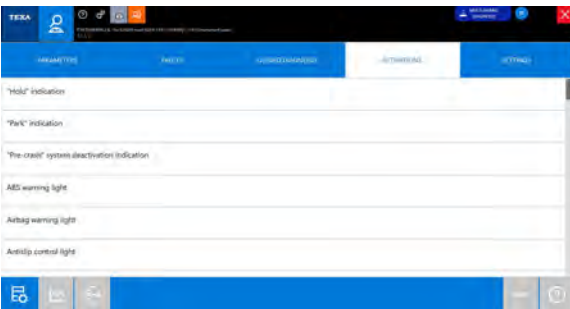

Advanced bi-directional testing including: compression test, fuel pump test, cylinder cut-off, fan test, and more.

# TEXA IDC5 Software



## DASHBOARDS



Using IDC5 dashboards the technician can see a visual representation of engine, ABS, transmission, and diesel exhaust data.



## WIRING DIAGRAMS

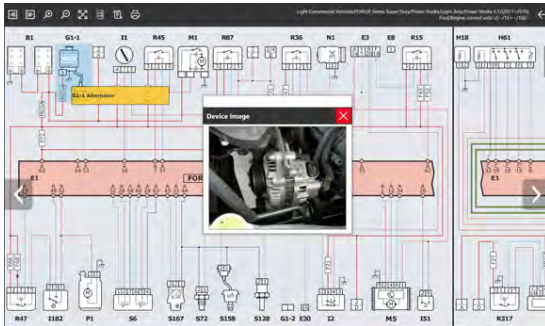

Interactive wiring diagrams with component locations and technical data sheets.



## REPAIR PROCEDURES

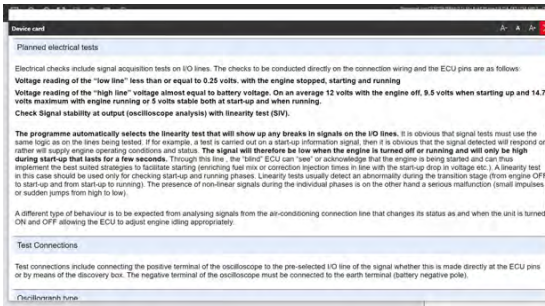

Users can find detailed instructions and comprehensive information regarding mechanical specifications, component locations, routine maintenance, service resets, component testing, and more.

# Specialists in the calibration of ADAS systems

Designed to guarantee safety and comfort while driving, the ADAS (Advanced Driver Assistance Systems) are ever more common in latest-generation vehicles.

Cameras, radars, LIDARs and sensors must be re-calibrated when replaced, but even when actions that affect them are required, such as: **replacing the windscreen and bumper, repairing the suspensions, aligning the wheels, changing the tyres, replacing the engine control unit, etc.**

Knowing how to intervene in this field is strategical to keep pace with the times and be able to offer customers first-class assistance.

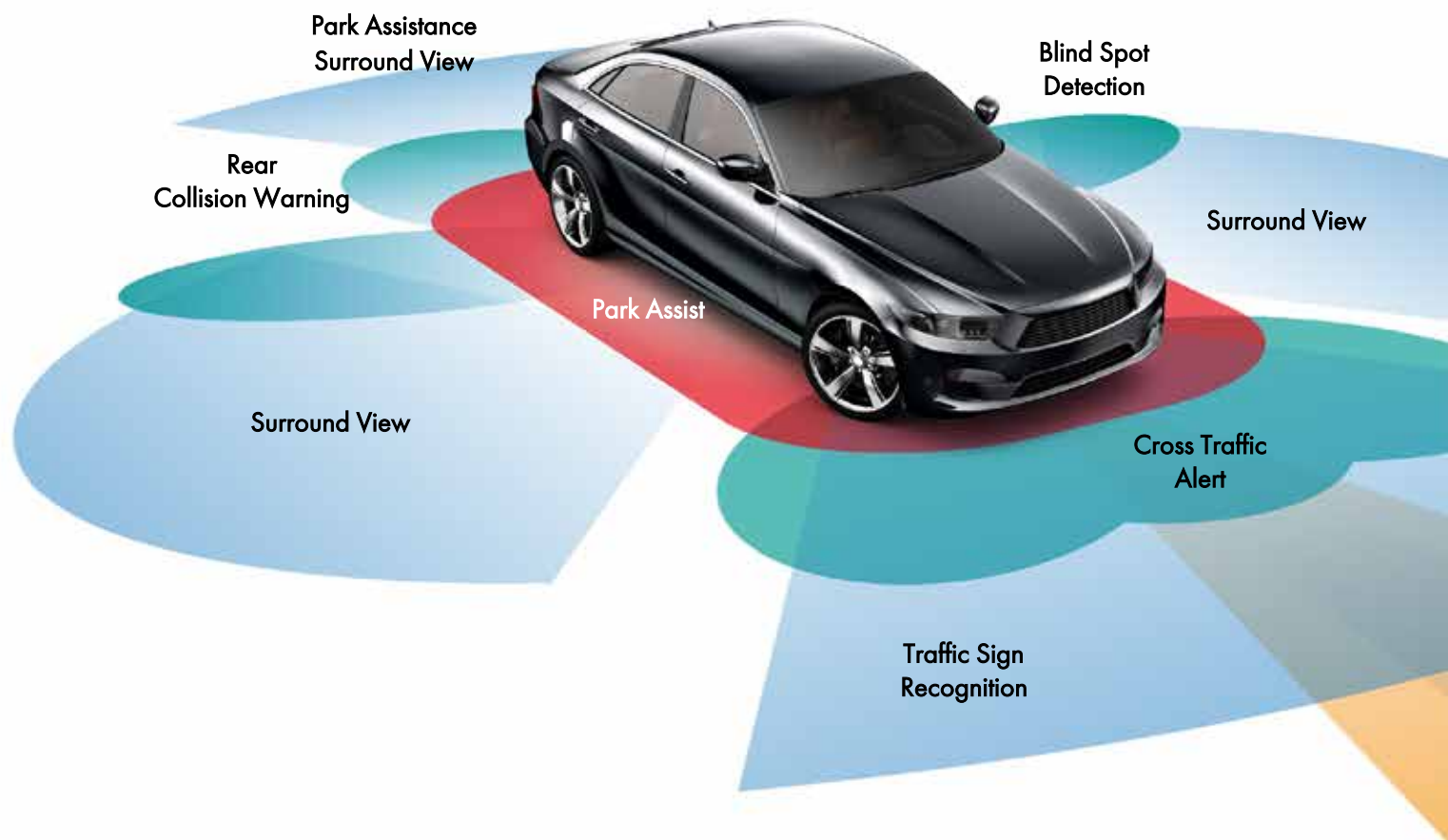



# A complete offer

TEXA helps automotive professionals successfully scan, repair, and calibrate complex vehicles with a **complete multi-brand offer** that includes:

- RCCS 3 (Radar and Camera Calibration System 3) available in two versions
- A large availability of specific panels and accessories

TEXA's solutions allow performing **static and dynamic calibrations** and resetting the ADAS correctly, **guaranteeing the safety** of drivers and technicians who carries out the diagnosis and calibrations.

The **IDC5 software** guides mechanics step-by-step throughout all the phases, thanks to the **technical data sheets** developed for each vehicle, offering expansive **CAR** and **TRUCK** coverage.



Lane Departure  
Warning

Emergency Braking  
Pedestrian Detection  
Collision Avoidance

Adaptive Cruise  
Control

- Long-Range Radar (~250 m)
- LIDAR (~150 m)
- Camera (~80 m)
- Short/Medium Range Radar (~20 m)
- Ultrasound (2-4 m)

# RCCS3

## two versions for a world class solution

The unit, designed and engineered by TEXA, is available in two versions: **RCCS 3 BT with Monitor** and **RCCS 3 BT with Targets**.

Both include **maximum constructive technology** and exceptional components.

RCCS 3 BT with Monitor is the top product in terms of performance and speed as it uses the digital representation of the panels, whereas RCCS 3 BT with Panels is intended to guest physical targets.

TEXA's solutions guarantee vast handling possibilities through a simple, quick, and precise adjustment. Two versions, two ways to approach work, but a unique result: **maximum safety for drivers and technicians performing the calibrations**, made possible by the high efficiency and precision of RCCS 3 BT.



*RCCS 3 with  
Monitor*

*RCCS 3 with  
Targets*



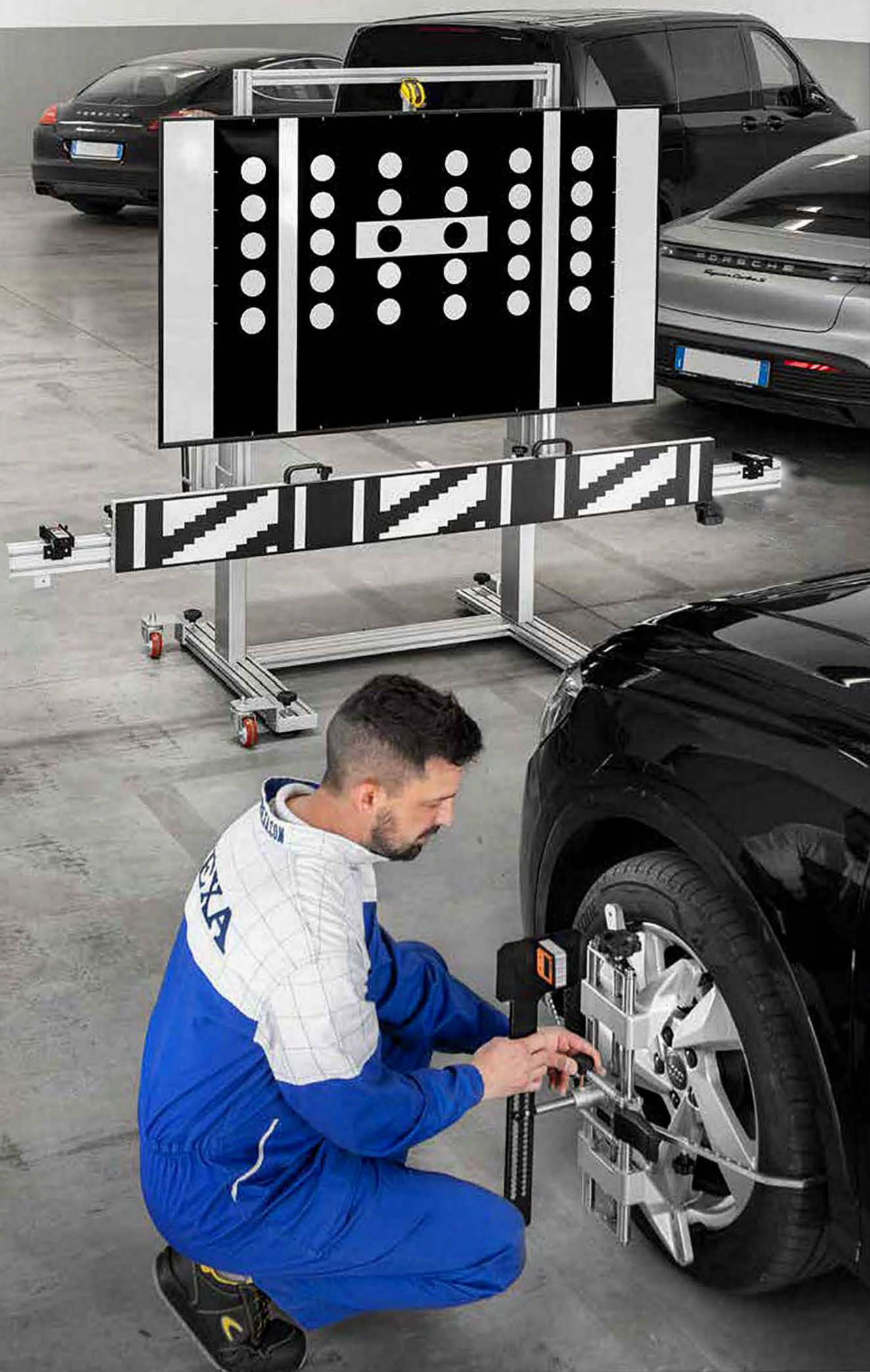

# RCCS 3 with Monitor

## the digital innovation for calibrating ADAS

RCCS 3 with Monitor is TEXA's solution for setting radars, LIDARs, cameras and sensors through the digital representation of the panels.

In fact, it is equipped with a **75-inch HD screen, 4K definition**, which always offers an optimal display, meeting the 1:1 proportion ratio in line with the specifications of every manufacturer.

Furthermore, it is important to highlight that it does **not deform nor resize** the images.

This way workshops are sure to operate in the most proper and safe way, without risking to alter the vehicle's behaviour on the road.

RCCS 3 communicates with the IDC5 software and guides the mechanic, step-by-step, to the quick and automatic identification of the vehicle. The panel is selected and set in the monitor, with no possibility of error.

Thanks to continuous **software updates** that each time offer new vehicles and eventually new panels, and to the essential **help sheets** edited per make and model, users are sure to complete any operation with maximum precision and to the highest standards, relying on an extraordinary coverage.

Furthermore, the digitalisation of the panels allows **clearing considerable space in the workshop** that would otherwise be occupied by multiple physical panels.

Livella laser



Front radar pointing  
laser

VAG 360° camera  
calibration mats



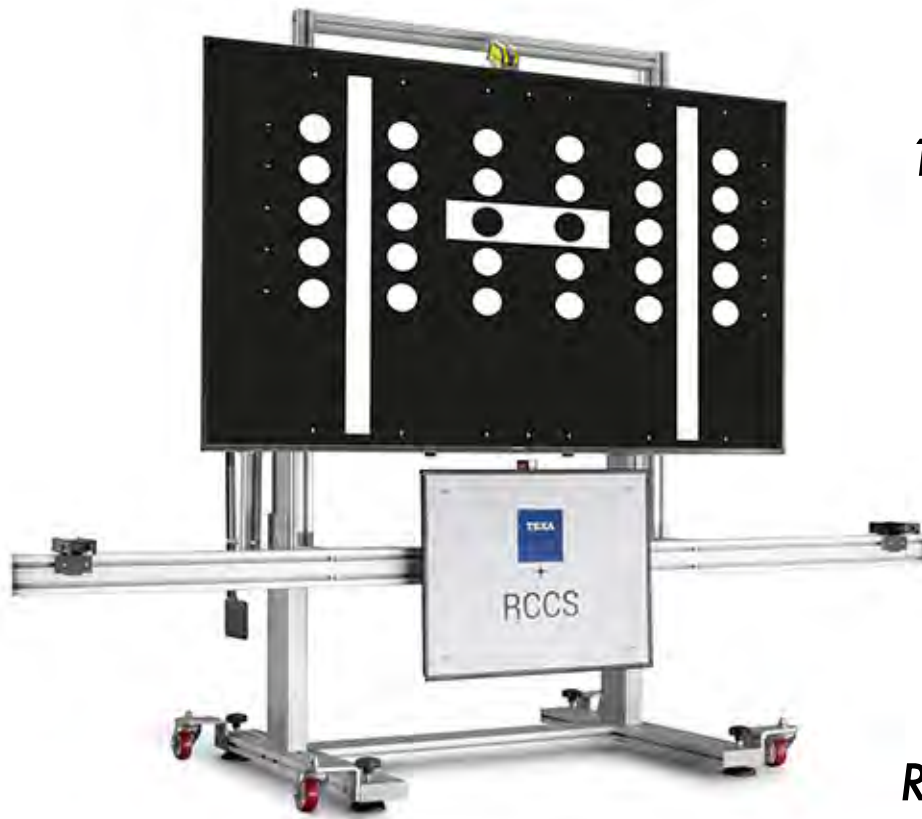

*1:1 proportion ratio in line with the specifications of every manufacturer*

*Robust, but easy to move and adjust*

*Easy to use thanks to the digitalisation of the panels*



Clamp on wheel rim with CCD electronic detector

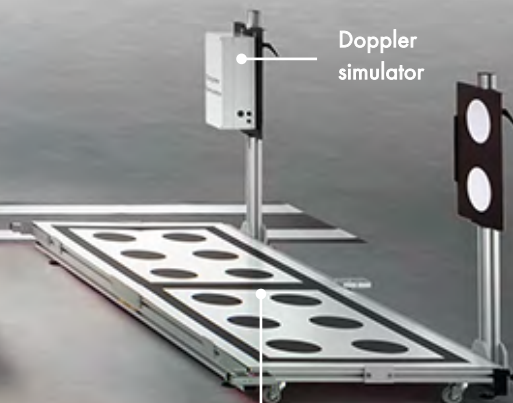

ACS device

Doppler simulator

# Intelligence and safety thanks to the Mini "on-board" PC

An actual Mini PC built into the unit, installed in the version RCCS 3 with Monitor, guarantees the use of an intelligent system that synchronises the ICD5 software and the TEXA unit perfectly.





The **images** of the targets are transmitted and **positioned automatically**, based on the vehicle selection made. They are displayed through a linear, safe and quick process.



# Positioning with Bluetooth distance measurers

## A new guided procedure

Thanks to a clear and precise messaging system all the vehicle preparation phases are extremely easy and quick. The software will guide the operator step by step to position the RCCS 3 unit safely.





Below there is a practical example of **positioning the unit** using the dedicated software:

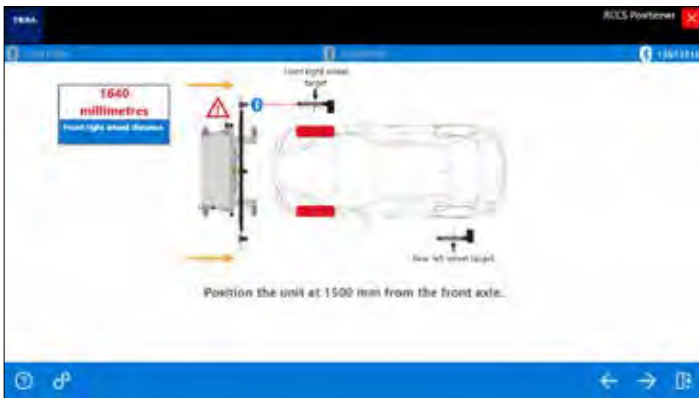

Place the provided clamps on the indicated points to start the guided positioning procedure.

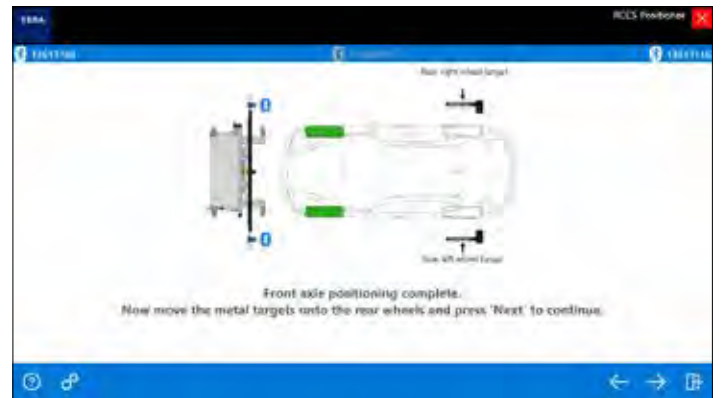

Front axle positioning completed successfully, proceed with the rear axle.

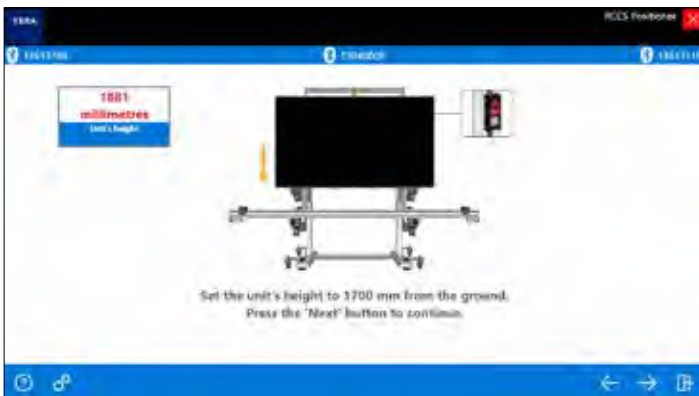

The unit must be moved electrically in order to position it at the correct height.

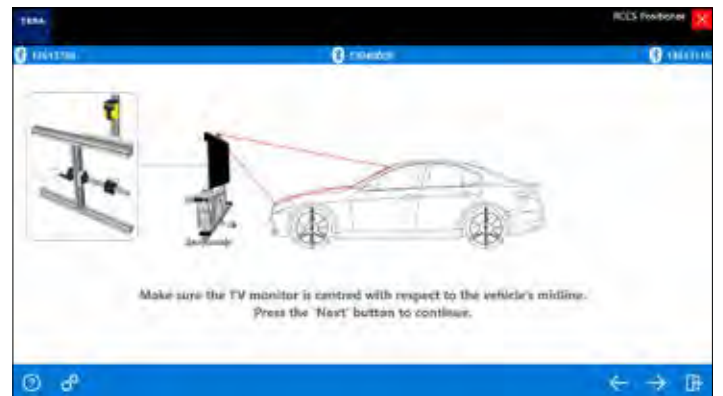

Centre the TV monitor with respect to the vehicle using the specific micro-adjustment.

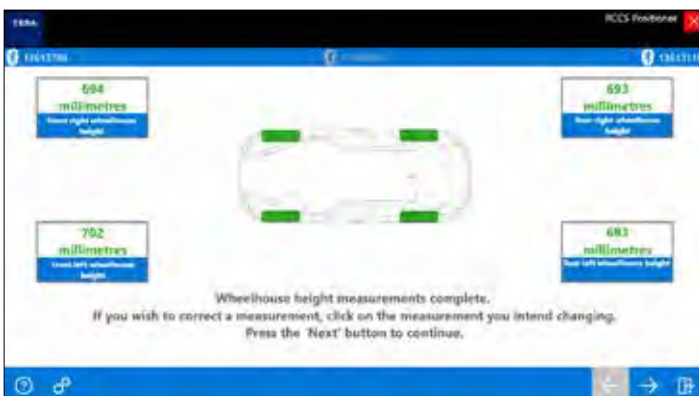

The unit is properly aligned with the vehicle, proceed with the calibration of the radar or camera.



Once the unit is positioned, proceed with the chosen diagnostic function.

# Precise, simple and quick adjustments and movements

RCCS 3 is made up by a very robust main support, which height can be adjusted thanks to its electrical operation. Using practical knobs, it can be easily tilted to the side and forward.

A handwheel and a laser level allow also performing millimetric side movements. On top of the unit there is another laser level, very useful for finding the centre of the vehicle simply pointing it onto the front logo.

The horizontal adjustment bar is equipped with two distance measurers and a reflecting plate, the latter with a central laser for the front radar's aiming.

RCCS 3 is easy to move within the workshop thanks to its oversized pivoting wheels.

This technological equipment allows positioning RCCS 3 and aligning it correctly with respect to the vehicle and to the ground easily, with absolute precision and in complete safety.

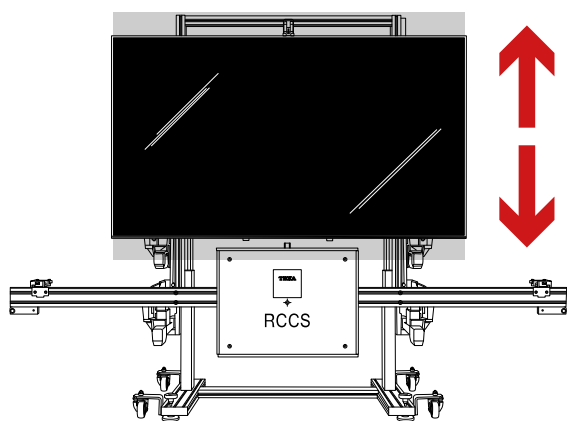

**Upward moving**

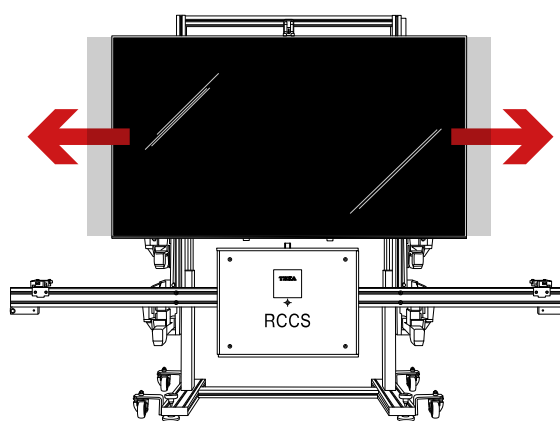

**Side shifting**  
*only in the version with Monitor*

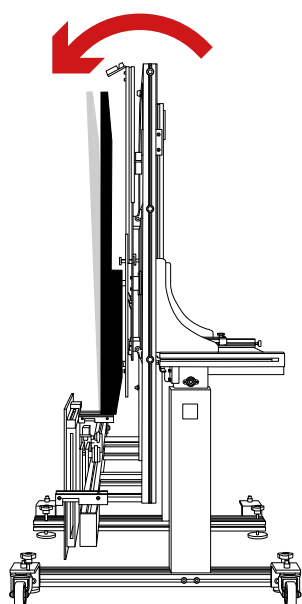

**Forward tilting**  
*only in the version with Monitor*

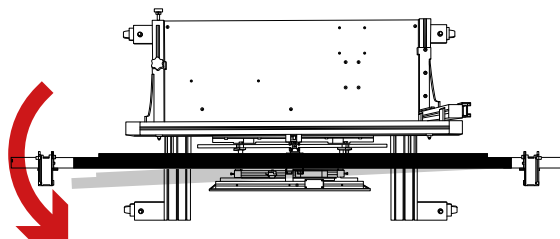

**Side tilting**

Side shifting  
only in the version with Monitor



*Side tilting  
Version with Monitor and with Panels*





*Forward tilting  
only in the version with Monitor*



*Centre laser*



*Reinforced structure and oversized wheels*

# Using the IDC5 software

## you have all the information to support all operations

TEXA's solutions must be used in combination with the IDC5 diagnostic software that allows completing any operation quickly.

In fact, the application provides specific **diagnostic help sections** for each make/model, with the instructions (such as panel height, distance from the vehicle, alignment, etc.) for the **correct positioning of the unit**, guiding you step-by-step throughout the procedures.

Furthermore, at the end of the calibration, you can print a report to hand over to the customer with the evidence of the operations carried out.

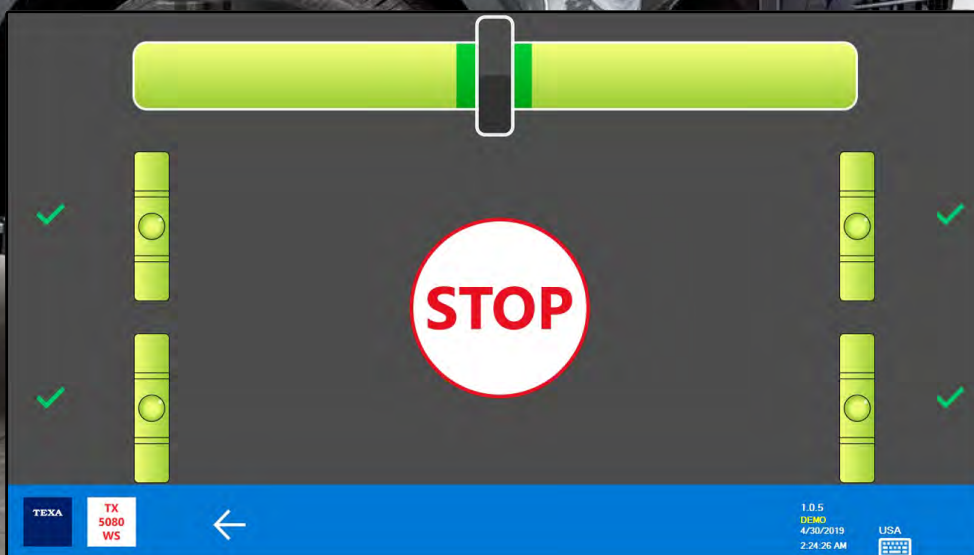
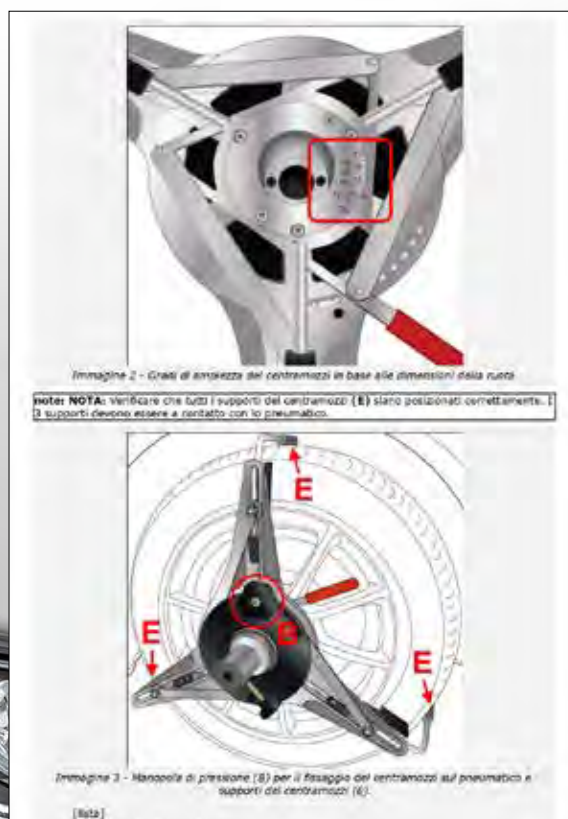
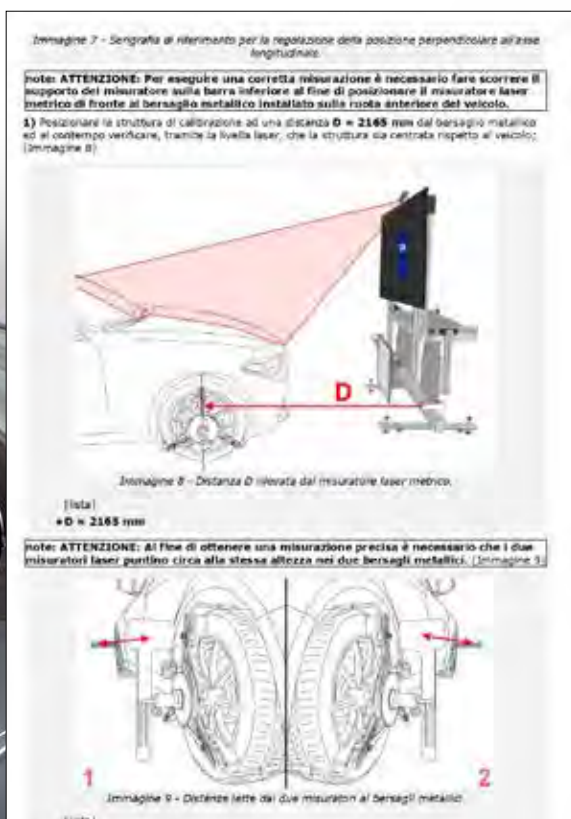



# A large range of accessories for a complete solution

TEXA's ADAS solutions can be used in combination with other optional devices to work in depth on other electronic driver assistance systems, among which:

## ACS (All-Around Calibration System)

ACS allows calibrating 360° cameras and Dopplers\* for VW Group (AUDI, VOLKSWAGEN, LAMBORGHINI) vehicles.

It is made up by an aluminum structure that has two horizontal panels and two vertical magnetic boards. The base has three housings for three distance measurer dedicated to verifying the correct alignment with respect to the vehicle.

TEXA's solution is featured by a **great practicality** being equipped with wheels that allow moving quickly within the workshop.



\* The rear and side radars can be calibrated using the TEXA Doppler Simulator.



## IR Calibration Target and Night Vision System

They are two very useful accessories as they allow **calibrating the infrared camera**, in a short time and with maximum precision, for the **Mercedes** and **VW Group** vehicles in which it is installed. It is an essential device from the point of view of road safety, which helps drivers detect in advance people or animals in the dark. Positioned in front of the vehicle, the IR Calibration Target and Night Vision System **simulate the presence of a warm body**.



## Blind spot radar reflector

It is an essential device for calibrating the ultrasonic radars installed in vehicles of the makes **HYUNDAI, HONDA, KIA, LEXUS, MAZDA, MITSUBISHI, SUBARU, TOYOTA**. It is made up by a metal reflector cone, a laser and a goniometer jig to help the technician position the pyramid cone correctly. It can be used both for the **front radars** and for the **side and rear radars**.



## Doppler Simulator

This accessory also is needed to calibrate the blind spot radar. However, in this case it is an active simulator that responds to the frequency generated by the rear radar in **MAZDA** and **VW Group** vehicles.



## 360° mats for TOYOTA, LEXUS, SCION and SUZUKI

A modular kit that allows calibrating the 360° vision system in TOYOTA, LEXUS, SCION and SUZUKI vehicles equipped with this technology.

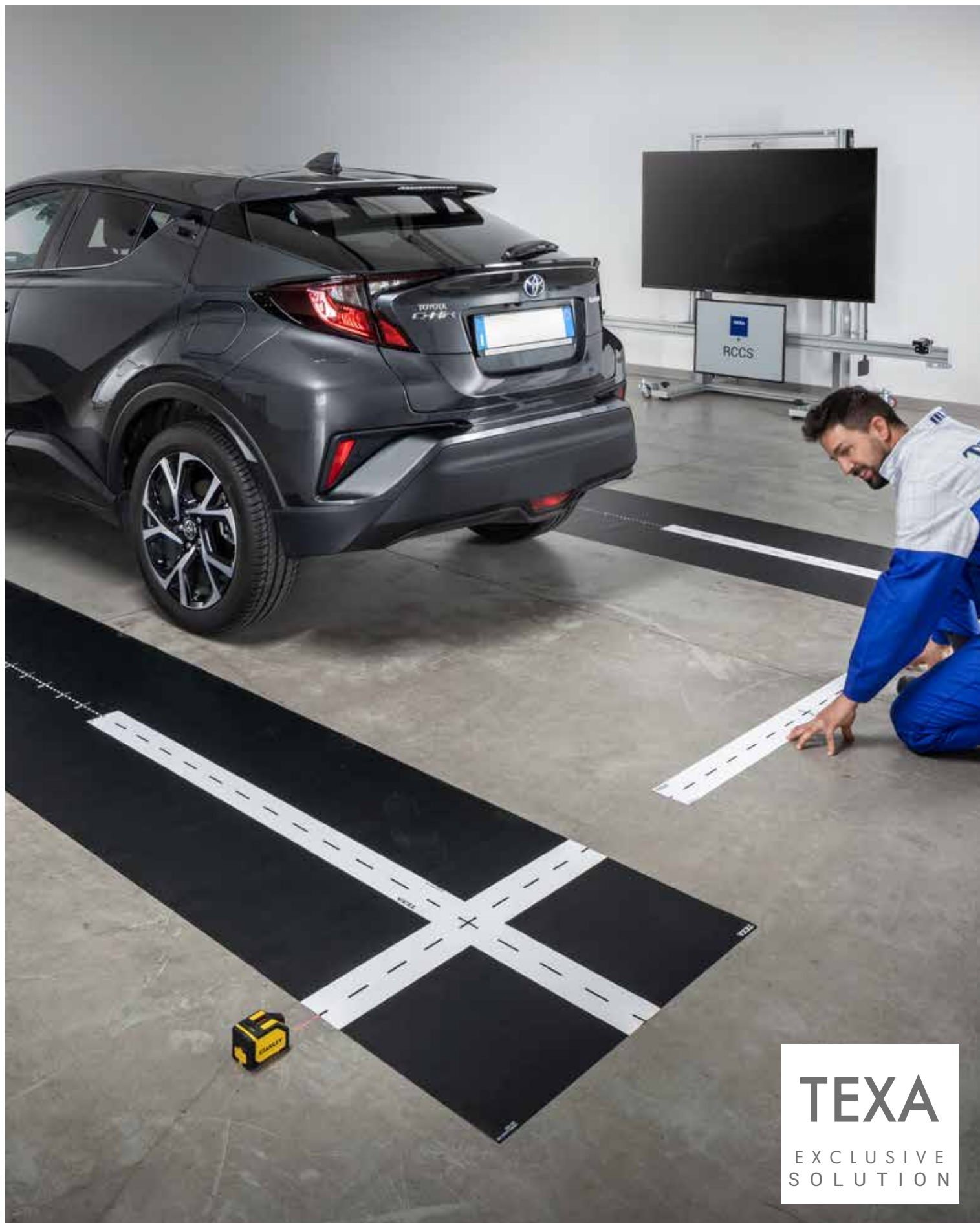

**TEXA**

EXCLUSIVE  
SOLUTION

# Calibration targets and accessories

For the calibration of the ADAS, TEXA offers a wide range of targets and specific accessories, which guarantee the most complete coverage in the market worldwide.

## Front Camera calibration targets



CITROEN/PEUGEOT, KIA/HYUNDAI,  
FIAT 500X, FIAT DUCATO X290, JEEP  
RENEGADE Type 2  
(front)



MAZDA  
(front)



MERCEDES  
(front)



MAZDA Type 2  
(front)



NISSAN/INFINITI  
(front)



SUBARU with calibration jig  
(front)



NISSAN Type 1  
(front)



MITSUBISHI/SUZUKI  
(front)



NISSAN Type 2  
(front)



KIA/HYUNDAI  
(front)



SMART  
(front)

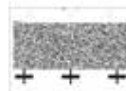

SUBARU EYESIGHT2  
(front)



VW  
(front)



MASERATI LEVANTE  
(front)



TOYOTA Type 1  
(front)

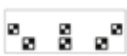

TOYOTA Type 2  
(front)



HONDA  
(front)



HONDA Type 2  
(front)











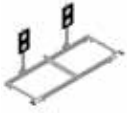



ALFA ROMEO Type 1  
(front)









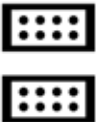

The targets can be perfectly integrated with the RCCS 3

Check the complete and always up-to-date ADAS coverage: [www.texausa.com/diagnostic-coverage](http://www.texausa.com/diagnostic-coverage)

## Radar calibration devices and additional kits

	ACS (All Around Calibration System)		Blind spot cone support kit
	Doppler Simulator VW and MAZDA		Blind spot cone TOYOTA/SUBARU/HONDA
	Radar Calibration Frame MAZDA		Blind spot cone KIA/HYUNDAI/MAZDA
	VW night vision (front)		Blind spot cone MITSUBISHI
	MERCEDES night vision (front)		Positioning jigs Parking sensors TOYOTA/LEXUS/SCION <b>NEW</b>
	Positioning jig kit RADAR VOLVO		Right/Left side rear-view mirror camera calibration panel for HONDA/ACURA <b>NEW</b>
	LASER SCANNER (LIDAR) VW (front)		

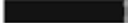
## CAR 360°/rear camera calibration

	VAG (rear)		MITSUBISHI (rear)
	VAG (360° cam.)		MITSUBISHI, NISSAN, MAZDA (360° cam.)
	MERCEDES Type 1 (rear)		KIA/HYUNDAI (rear)
	MERCEDES Type 2 (rear)		NISSAN (rear)
	CADILLAC		Calibration band 360° camera for HONDA/ACURA
	TOYOTA, LEXUS, SCION, SUZUKI (360° cam.)		

# TEXA

Founded in Italy in 1992, TEXA is today a world leader in the design, industrialisation and production of multi-brand diagnostic tools, exhaust gas analysers, air conditioning charging stations and telediagnostic devices, for cars, bikes, trucks, boats, and agricultural vehicles. TEXA is present all over the world with a widespread net of distributors: it commercialises directly in Brazil, France, the UK, Germany, Japan, Spain, the US, Poland and Russia through its subsidiaries. TEXA currently employs more than 700 people around the world, including over 150 engineers and specialists working in Research and Development. Over the years, TEXA has received a large number of prizes and awards for innovation, in many countries worldwide. All TEXA tools are designed, engineered and built in Italy, using extremely modern automated production lines which guarantee maximum precision. TEXA is particularly committed to the quality of its products: it obtained the strictest certifications, such as the TISAX (Trusted Information Security Assessment Exchange), a standard defined by the VDA, the German Association of the Automotive Industry, which guarantees the highest level possible of information and know-how protection against increasingly frequent cyber-attacks. It joins other certifications, such as the IATF 16969, specific for first automotive suppliers; the VDA 6.3, another method by German manufacturers that established itself as an international point of reference; and the ISO/IEC 27001 in the information security field.

## WARNING

The trademarks and logos of vehicle manufacturers in this document have been used exclusively for information purposes and are used to clarify the compatibility of TEXA products with the models of vehicles identified by the trademarks and logos. Because TEXA products and software are subject to continuous developments and updates, upon reading this document they may not be able to carry out the DIAGNOSTICS of all the models and electronic systems of each vehicle manufacturer mentioned within this document. References to the makes, models and electronic systems within this document must therefore be considered purely indicative and TEXA recommends to always check the list of the "Systems that can be diagnosed" of the product and/or software at TEXA authorised retailers before any purchase. The images and the vehicle outlines within this document have been included for the sole purpose of making it easier to identify the vehicle category (car, truck, motorbike, etc.) for which the TEXA product and/or software is intended. The data, descriptions and illustrations may change compared to those described in this document. TEXA S.p.A. reserves the right to make changes to its products without prior notice.



To check out the extensive coverage of TEXA products, go to:

[www.texausa.com/coverage](http://www.texausa.com/coverage)

To check on IDC5 compatibility and minimum system requirements, go to:

[www.texausa.com/system](http://www.texausa.com/system)

The Bluetooth® brand is the property of Bluetooth SIG, Inc., U.S.A., and is used by TEXA S.p.A. under license.

Android is a trademark of Google Inc



[facebook.com/texausa](https://facebook.com/texausa)



[www.linkedin.com/company/texa-usa-inc/](https://www.linkedin.com/company/texa-usa-inc/)



[www.instagram.com/texa\\_usa/](https://www.instagram.com/texa_usa/)



[youtube.com/texa\\_usa](https://youtube.com/texa_usa)

Copyright TEXA S.p.A. cod.  
8800662  
01/2022 - Inglese - V18

TEXA USA Inc.  
409 Joyce Kilmer Ave New  
Brunswick, NJ, 08901  
[www.texausa.com](http://www.texausa.com)  
[northamerica@texa.com](mailto:northamerica@texa.com)+1  
855.200.8392

COMPANY WITH  
QUALITY SYSTEM  
CERTIFIED BY DNV  
ISO 9001